

White Paper on Co-Location System Isolation of a Sub-3GHz Antenna and a C-band NR Antenna

Issue V1.0
Date 2019-03-20

Copyright © Huawei Technologies Co., Ltd. 2019. All rights reserved.

No part of this document may be reproduced or transmitted in any form or by any means without prior written consent of Huawei Technologies Co., Ltd.

Trademarks and Permissions



HUAWEI and other Huawei trademarks are trademarks of Huawei Technologies Co., Ltd.

All other trademarks and trade names mentioned in this document are the property of their respective holders.

Notice

The purchased products, services and features are stipulated by the contract made between Huawei and the customer. All or part of the products, services and features described in this document may not be within the purchase scope or the usage scope. Unless otherwise specified in the contract, all statements, information, and recommendations in this document are provided "AS IS" without warranties, guarantees or representations of any kind, either express or implied.

The information in this document is subject to change without notice. Every effort has been made in the preparation of this document to ensure accuracy of the contents, but all statements, information, and recommendations in this document do not constitute a warranty of any kind, express or implied.

Huawei Technologies Co., Ltd.

Address: Huawei Industrial Base
Bantian, Longgang
Shenzhen 518129
People's Republic of China

Website: <http://www.huawei.com>

Email: support@huawei.com

Abbreviation List

Abbreviation	Full Name
AMP	Amplifier
ANT	Antenna
BS	Base Station
DAC	Digital-to-analog Converter
FDD	Frequency Division Duplex
GSM	Global System For Mobile Communications
LTE	Long Term Evolution
LNA	Low Noise Amplifier
NR	New Radio
PA	Power Amplifier
Q MOD	Quadrature Modulator
RX	Receiver
TDD	Time Division Duplex
TRX	Transmitter And Receiver
TX	Transmitter
UMTS	Universal Mobile Telecommunications System

Contents

1 Inter-System Influencing Factors.....	1
1.1 About This Document.....	1
1.2 Spurious Interference.....	1
1.2.1 Spurious Interference Generation Mechanism.....	1
1.2.2 Impact of Spurious Interference on the Receiver	2
1.3 Blocking Interference	3
1.3.1 Blocking Interference Generation Mechanism	3
1.4 Impact on Antenna Patterns	4
2 Requirements for Antenna Isolation.....	5
2.1 Background Introduction.....	5
2.2 Antenna Isolation Requirement Calculation Based on Spurious Interference	5
2.3 Antenna Isolation Requirement Calculation Based on Blocking Interference	9
2.4 Isolation Requirement for Multi-TRX Antennas	11
2.5 Conclusion.....	12
3 Isolation Calculation of Antennas Installed Horizontally and Horizontal Installation Distance Between Sub-3GHz Antennas and C-band NR Antennas	13
3.1 Theoretical Calculation of Isolation Between Two Antennas Horizontal Deployment	13
3.2 Test Result of Sub3GHz Antenna and C-band NR Antenna When They Are Placed Horizontally with Distance of 0.1 m.....	14
3.3 Simulation of Impact of Horizontal Distance On Antenna Patterns.....	16
3.4 Conclusion.....	18
4 Isolation Calculation of Antennas Installed Vertically and Vertical Installation Distance Between Sub-3GHz Antennas and C-band NR Antennas	19
4.1 Theoretical Calculation of Isolation Between Two Antennas Vertical Deployment	19
4.2 Test Result of Vertical Isolation Between a Sub3GHz Antenna and a C-band NR Antenna Without Spacing	20
4.3 Simulation of Impact of Vertical Distance On Antenna Patterns	23
4.4 Conclusion.....	23
5 Isolation Calculation of Antennas Installed Slantly and Slant Installation Distance Between Sub-3GHz Antennas and C-band NR Antennas	24
5.1 Theoretical Calculation of Isolation Between Two Antennas Slant Deployment.....	24
5.2 Conclusion.....	25

6 Inter-System Deployment in One Region Using Different Base Stations.....	26
7 Summary	28

1 Inter-System Influencing Factors

1.1 About This Document

With the development of mobile communications technologies, operators have a strong requirement for a co-located deployment of multiple bands and systems. They are concerned about the isolation between multiple systems at a base station site, in particular about the levels of spurious signals and blocking between a Sub-3GHz antenna and a 3.5 GHz New Radio (NR) antenna. This white paper illustrates the requirements on isolation and antenna installation distance for the co-location deployment of NR and other radio access technologies (RATs).

1.2 Spurious Interference

1.2.1 Spurious Interference Generation Mechanism

The transmitter consists of nonlinear components such as the quadrature modulator (Q MOD), driving amplifier (AMP), and power amplifier (PA), which generate intermodulation and harmonics. Such intermodulation, harmonics, and broadband thermal noise of the transmitter cause spurious emission. If spurious levels are high and their spectral components occur within the receive frequency band of an active receiver at this site, as shown in the following figure, spurious interference occurs.

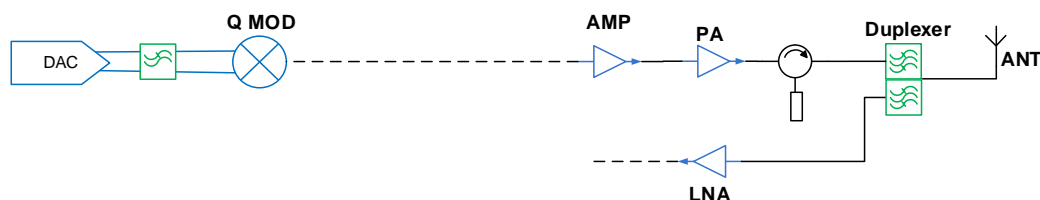

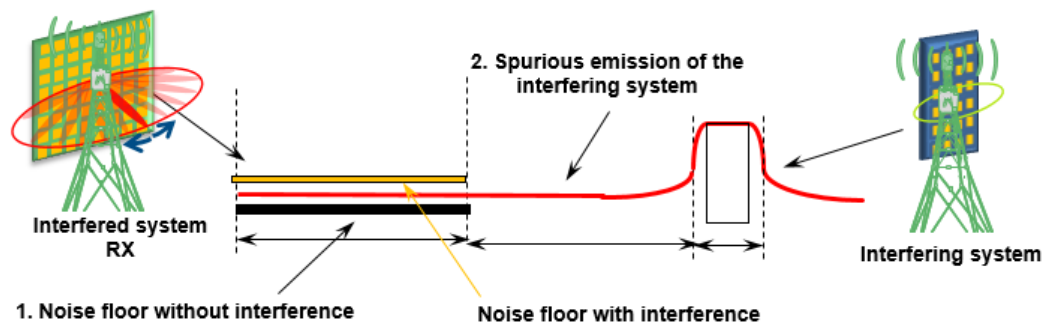

The noise floor without interference of the receiver is intrinsic noise, including thermal noise and noise related to the noise factor of the receiver. If the noise factor of the receiver is NF_{RX} in the unit of dB, N_{nf} (noise floor without interference) represents the intrinsic noise of the receiver converted to its input port in the unit of dBm. The formula is as follows:

$$N_{nf} = -174 + NF_{RX} + 10\log BW \quad (1.2.1)$$

BW represents receive noise bandwidth in the unit of Hz.

The receiver performance analysis may start with the degradation of the receiver sensitivity caused by noise and/or interference. The receiver sensitivity, S_{min} , is in the unit of dBm.

$$S_{min} = -174 + 10\log(BW) + NF_{RX} + CNR_{min} \quad (1.2.2)$$

A wireless communication system requires a minimum carrier-to-noise/interference ratio (CNR_{min}) to achieve a given data error rate such as bit error rate (BER) and frame error rate (FER). Therefore, it is apparent that an increase of noise floor at the receiver results in a degradation of the sensitivity ΔS (unit: dB). The increase is calculated using N_{nf} and N_i (spurious interference) in the interfered system RX band and can be calculated as follows:

$$N_i = N_{nf} + 10\log(10^{\Delta S/10} - 1) \quad (1.2.3)$$

1.2.2 Impact of Spurious Interference on the Receiver

Generally, the noise factor NF_{RX} of a macro base station is about 2 dB to 3 dB.¹

Assuming that NF_{RX} equals 2 dB and the normalized BW is 1 MHz, the following noise floor is calculated using the formula (1.2.1): $N_{nf} = -174 + 2 + 10\log(10^6) = -112$ dBm/MHz

According to the formula (1.2.3), the following figure shows the relationship between the sensitivity deterioration and the interference level.

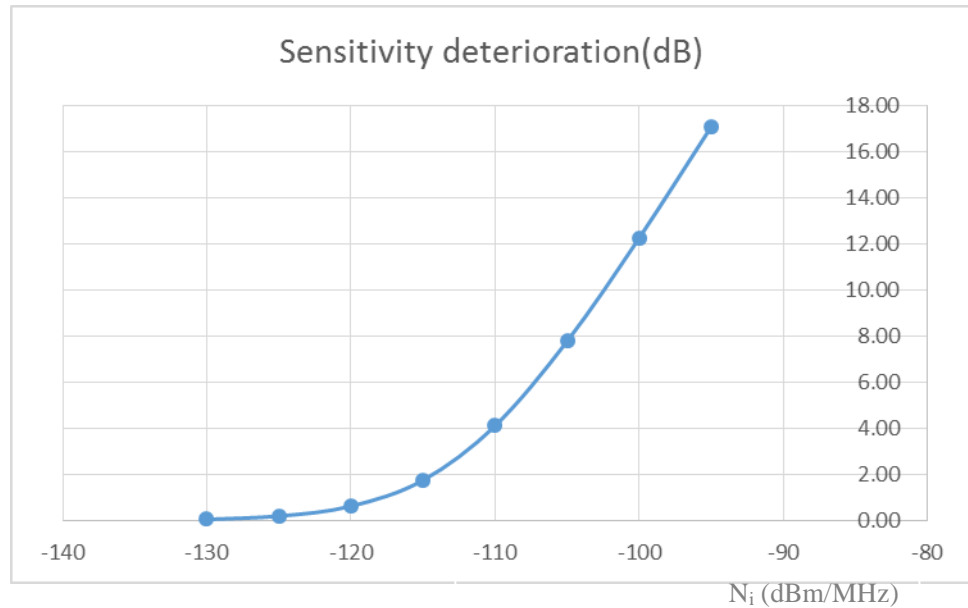

Example: When the total interference noise falling into the receiver of the interfered system is -118 dBm/MHz, the receiver sensitivity deteriorates by 1 dB.

NOTE

1. This is a value range commonly used in the industry. Some BTS providers may use different values. The specific data needs to be obtained from the BTS providers.

1.3 Blocking Interference

1.3.1 Blocking Interference Generation Mechanism

Blocking interference is generally caused by the insufficient capability of the receiver's radio frequency (RF) filter to suppress signals outside of its pass band. In this case, a portion of this (unwanted) signal will be present at the input of the RF low noise amplifier and may partially or fully mask a weak (wanted) receive signal, effectively deteriorating the sensitivity of the receiver similar to increased noise. Also, if the interval between the TX band of the interfering system and the RX band of the interfered system is small, TX signals of the interfering system can leak into the receiver and cause intermodulation products generated by the nonlinearities of the receiver. Those intermodulation products may fall into the RX band and, as a result, increase the noise floor and create interference.

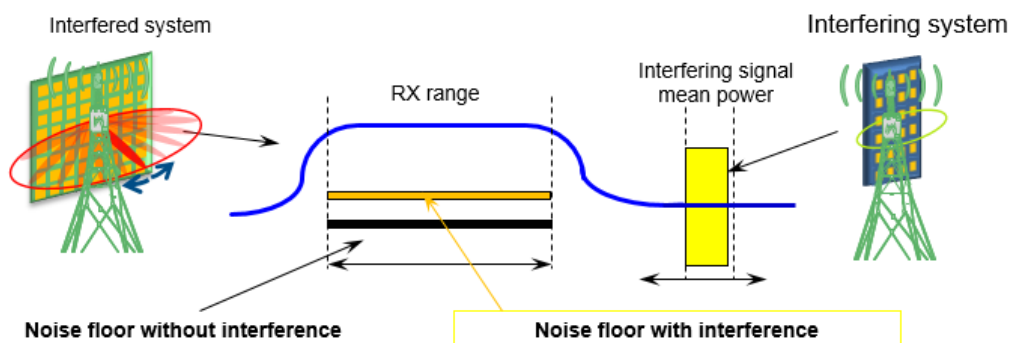

A base station receiver (such as the TDD receiver in the following figure) uses RF RX filters (pre-filter and RF-filter) to reject signals outside of the frequency band of the wanted RX signals. This protects the receiver from being interfered by noise and other external blocking signals. RF RX filters are band-pass filters that pass only signals within the pass-band frequency to the subsequent circuits. Spectral components outside of this pass band are attenuated to ideally insignificant levels. Whether the RF RX filters can sufficiently suppress the interference signals mainly determines whether the receiver of a base station is desensitized or even blocked.

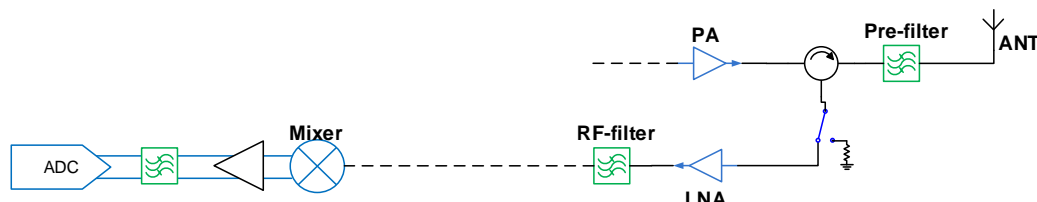

1.4 Impact on Antenna Patterns

Mutual coupling between antennas depends among other factors on the relative position of the antennas to each other. As the distance between antennas gets closer, mutual coupling between these antennas increases. As a result of such mutual coupling, antenna patterns become distorted and radio signal coverage is affected.

2 Requirements for Antenna Isolation

2.1 Background Introduction

In this document, the isolation of Sub-3GHz base station antennas must be considered when they share antenna installation platforms. These antennas may typically support 700 MHz (B28), 800 MHz (B20), 900 MHz (B8), 1500 MHz (B32), 1800 MHz (B3), 2100 MHz (B1), 2300 MHz (B40), FDD 2600 MHz (B7), and TDD 2600 MHz (B38) frequency bands. When these antennas are co-sited with C-band NR antennas, the isolation between those also needs to be considered. For details about definitions of B28, B20, B8, B32, B3, B1, B40, B7, and B38, see 3GPP TS 36.104. The following figures show typical antenna installation scenarios that require consideration of mutual coupling.

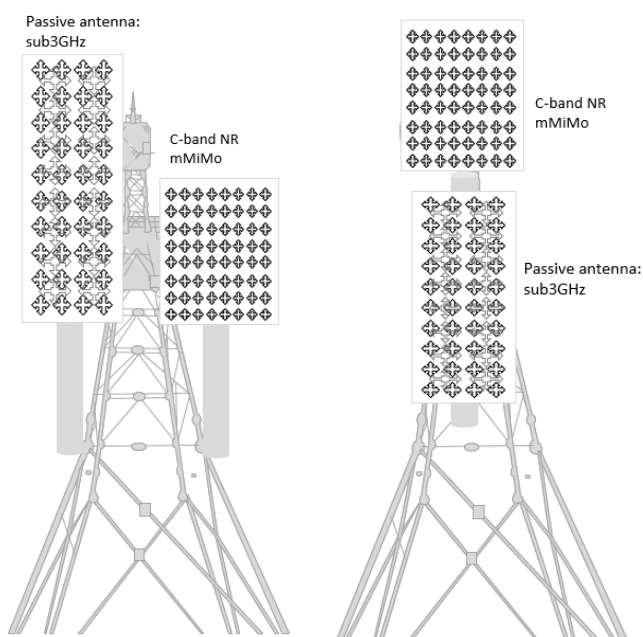

2.2 Antenna Isolation Requirement Calculation Based on Spurious Interference

Spurious interference isolation is calculated using the following formula:

$$I_{\text{spurious}} = P_{\text{emission}} - K_{\text{BW}} - L_{\text{Tx}} - L_{\text{Rx}} - M_{\text{Rx}} \quad (2.2.1)$$

I_{spurious} [dB]: Isolation between the interfering system and the interfered system in the case of spurious interference

$P_{emission}$ [dBm]: Spurious transmit power of the interfered system frequency band within the specified measurement bandwidth of the interfering transmitter

BW_{Tx} [kHz]: Test bandwidth of the interfering system

BW_{Rx} [kHz]: Carrier bandwidth of the interfered system

L_{Tx} [dB]: Feeder loss of the interfering system

L_{Rx} [dB]: Feeder loss of the interfered system

M_{Rx} [dBm]: Spurious power of the interfering system tolerable to the receive frequency band of the interfered system

K_{BW} [dB]: Bandwidth conversion coefficient

$$K_{BW} = 10 \times \log(BW_{Tx}/BW_{Rx})$$

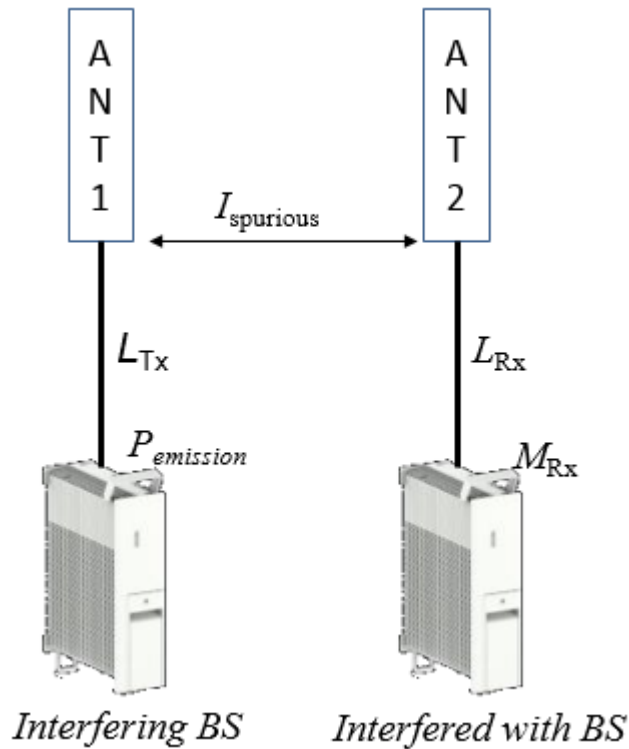

Assume that the values of BW_{Tx} and BW_{Rx} are 1 MHz. Thus, K_{BW} equals 0.

The following table lists the value of M_{Rx} (Note 2).

RAT	Normalized Level Value
GSM	-112 dBm/MHz
UMTS	-118 dBm/MHz

FDD LTE	-118 dBm/MHz
TDD LTE	-117 dBm/MHz
NR	-117 dBm/MHz



NOTE

Note 2: In the case of spurious interference, the sensitivity decreases by less than 1 dB for UMTS, LTE, and NR, and the sensitivity decreases by less than 3 dB for GSM. The level of spurious emission differs depending on operators' requirements.

The following factor must be considered for the value of $P_{emission}$ [dBm]:

To prevent spurious interference, 3GPP specifications propose the following requirements in the case of out-of-band spurious emission of a base station in co-siting scenarios: Assuming that there is 30 dB isolation between the transmitter and the receiver, the requirements in the following table must be met.

Type of Co-located BS	Frequency Range for Co-location Requirement	Basic Limit			Measurement Bandwidth
		WA BS	MR BS	LA BS	
Macro GSM900	876-915 MHz	-98 dBm	-91 dBm	-70 dBm	100 kHz
Macro DCS1800	1710-1785 MHz	-98 dBm	-91 dBm	-80 dBm	100 kHz
Macro PCS1900	1850-1910 MHz	-98 dBm	-91 dBm	-80 dBm	100 kHz
Macro GSM850 or CDMA850	824-849 MHz	-98 dBm	-91 dBm	-70 dBm	100 kHz
WA UTRA FDD Band I or E-UTRA Band 1 or NR Band n1	RX	-96 dBm	-91 dBm	-88 dBm	100 kHz

However, the frequency gap between Sub-3GHz base station antennas and C-band NR antennas is large. Therefore, the spurious emission level is 10 to 40 dB lower than the preceding values specified in 3GPP specifications.

The spurious emission of the transmitter in the interfering system mainly includes the noise floor, intermodulation, and harmonic spurious emission.

The following figure shows a typical spectrum of the intermodulation products of two unmodulated signals f_1 and f_2 of equal power levels P_c due to non-linear effects.

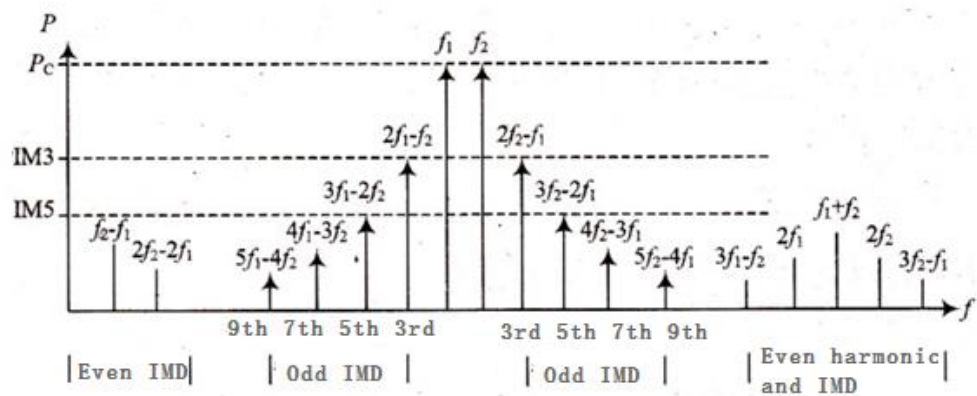

For any two tone intermodulation between the frequency bands 700 MHz (B28), 800 MHz (B20), 900 MHz (B8), 1500 MHz (B32), 1800 MHz (B3), 2100 MHz (B1), 2300 MHz (B40), FDD 2600 MHz (B7) and TDD 2600 MHz (B38), only the fourth harmonic TX signals of 900 MHz and the second harmonic TX signals of 1800 MHz fall into the frequency band of the C-band NR bands B43.

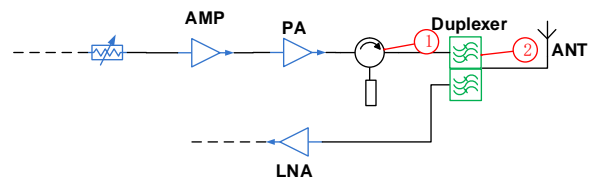

As the figure above, the thermal noise level at location ① is below -30 dBm/MHz, and the harmonic spurious level is below -10 dBm/MHz (Note 3) after PA output of the transmitter in the macro base station (with P_{max} greater than 43 dBm). Spurious emission and thermal noise are suppressed by the TX filter of the duplexer. The frequency spacing between the Sub-3GHz base station antenna bands and the C-band NR frequency band is greater than 700 MHz. The TX filter of the base station or NR may provide suppression greater than 90 dB (Note 3). Therefore, the spurious level at location ② decreases by more than 90 dB when compared with that at location ①. Therefore, the impact of spurious emission of 900 MHz and 1800 MHz on C-band NR is considered. The spurious level of C-band NR and Sub-3GHz base station antenna is below -120 dBm ($-30 - 90 = -120$). Therefore, they are not calculated separately.

Minimum inter-antenna isolation required by the 1800 MHz or 900 MHz base station receiver on C-band NR spurious emission can be calculated as follows:

$$M_{Rx} = -117 \text{ dBm/MHz (considering the RX sensitivity degradation } \leq 1 \text{ dB)}$$

$$L_{Tx} = 0.5 \text{ dB, } L_{Rx} = 0$$

$$K_{BW} = 0 \text{ (because of normalized BW)}$$

$$P_{\text{emission}} \text{ is } -100 \text{ dBm/MHz}$$

$$I_{\text{spurious}} = -100 - (-117) - 0.5 + 3 = 19.5 \text{ dB (considering 3 dB margin)}$$

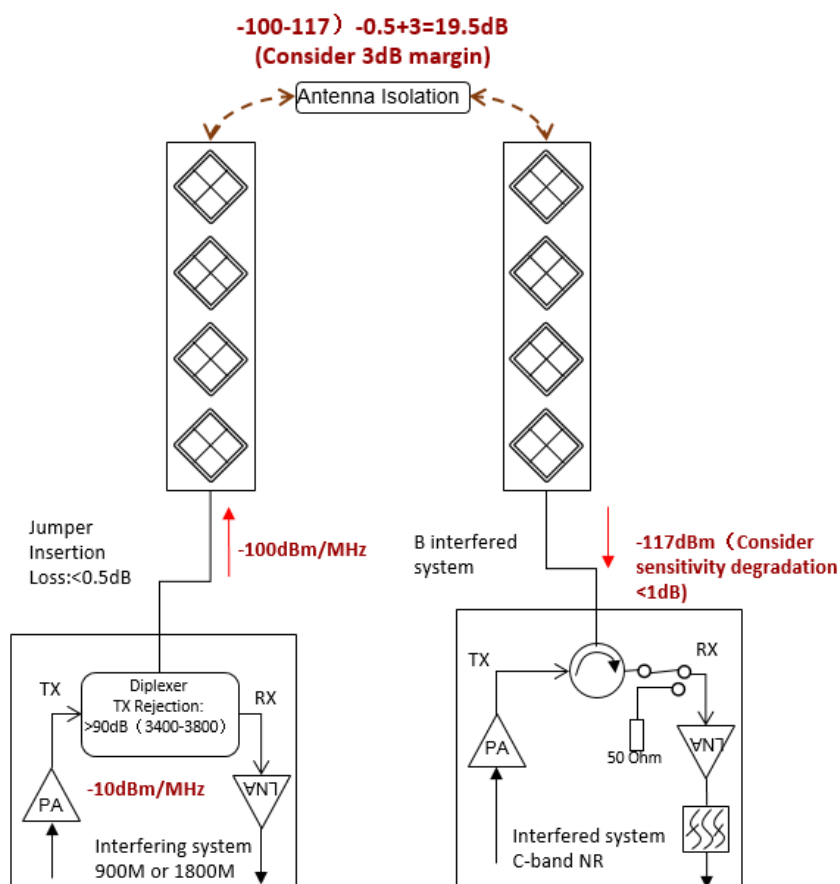

Considering the comprehensive impact of 700 MHz (B28), 800 MHz (B20), 900 MHz (B8), 1500 MHz (B32), 1800 MHz (B3), 2100 MHz (B1), 2300 MHz (B40), FDD 2600 MHz (B7), and TDD 2600 MHz (B38) on C-band NR, the antenna isolation requirements are calculated as follows:

$$P_{\text{emission}} = (-120 \text{ dBm}) + (-120 \text{ dBm}) + (-100 \text{ dBm}) + (-120 \text{ dBm}) + (-100 \text{ dBm}) + (-120 \text{ dBm}) + (-120 \text{ dBm}) + (-120 \text{ dBm}) + (-120 \text{ dBm}) = -96.8 \text{ dBm}$$

$$I_{\text{spurious}} = 96.8 - (-117) - 0.5 + 3 \text{ (Note 4)} = 23 \text{ dB}$$

Note 3: This value is a commonly agreed result in the industry. Still, other vendors may use different values. The specific value needs to be obtained from the equipment vendor.

Note 4: 3 dB is the interference margin.

2.3 Antenna Isolation Requirement Calculation Based on Blocking Interference

The formula for calculating the blocking interference isolation is as follows:

$$I_{\text{Blocking}} = P_{\text{Tx}} - L_{\text{Tx}} - L_{\text{Rx}} - P_{\text{Blocking}} \quad (2.3.1)$$

where

$I_{Blocking}$ [dB]: Isolation between the interfering system and the interfered system in the case of blocking interference

P_{Tx} [dBm]: Transmit power of the interfering system

L_{Tx} [dB]: Feeder loss of the interfering system

L_{Rx} [dB]: Feeder loss of the interfered system

$P_{Blocking}$ [dBm]: Tolerable blocking power

Note: 3GPP specifications allow that the sensitivity can be reduced by 6 dB in the case of co-sited blocking. In actual engineering, the sensitivity of UMTS and LTE decreases by less than 1 dB and that of GSM decreases by less than 3 dB in the case of blocking.

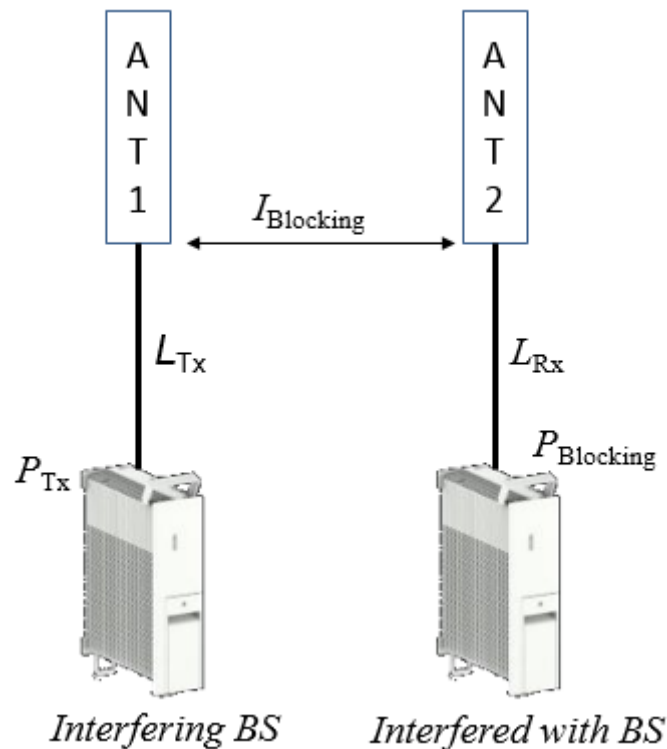

To prevent blocking interference, 3GPP TS 36.104 proposes the following requirements in the case of out-of-band blocking of a base station in co-siting scenarios: Assume that there is 30 dB isolation between the transmitter and the receiver, the requirements in the following table must be met.

Co-located BS type	Centre Frequency of Interfering Signal (MHz)	Interfering Signal mean power (dBm)	Wanted Signal mean power (dBm)	Type of Interfering Signal
Macro GSM850 or CDMA850	869 – 894	+16	$P_{REFSENS} + 6dB^*$	CW carrier

Macro GSM900	921 – 960	+16	$P_{\text{REFSENS}} + 6\text{dB}^*$	CW carrier
Macro DCS1800	1805 – 1880	+16	$P_{\text{REFSENS}} + 6\text{dB}^*$	CW carrier
Macro PCS1900	1930 – 1990	+16	$P_{\text{REFSENS}} + 6\text{dB}^*$	CW carrier
WA UTRA FDD Band TX or E-UTRA Band TX	TX Band	+16	$P_{\text{REFSENS}} + 6\text{dB}^*$	CW carrier

For the receiver, if the frequency spacing between point ① and the RF-filter passband is greater than 40 MHz and the block signal strength is -30 dBm , the sensitivity deterioration is less than 1 dB. Therefore, for Sub-3GHz base station antenna and C-band NR base stations, the anti-blocking signal strength is 60 dBm ($-30 + 90$) because the frequency band spacing is greater than 700 MHz. However, the TX signals of common base stations cannot reach such high levels, which means that there is no blocking problem.

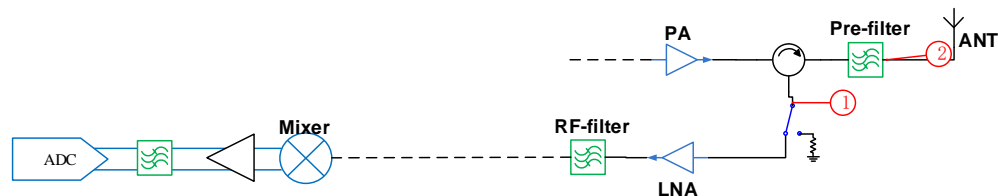

2.4 Isolation Requirement for Multi-TRX Antennas

2T2R, 4T4R, 8T8R, 16T16R, 32T32R, and 64T64R systems emerged with the development of spatial multiplexing technologies. Multi-TX spurious emission and blocking must be considered in $nTnR$ systems.

There are multiple arrays on one antenna installation platform. As a result, the isolation varies greatly with the relative position of the different arrays. In some scenarios, the isolation will reach 30 dB. If the worst value is used in the anti-interference design when calculating the interference impact of $nTnR$, the design is too conservative. Therefore, a new method for calculating the antenna isolation is required.

The definition of the comprehensive isolation is as follows: The sum of isolation (as shown in Figure 1) of n antenna arrays $\{T1, T2, \dots, Tn\}$ and another antenna array Y , denoted as $C_{(T1,Tn)-Y}$, meets the following equation:

$$C_{(T1,Tn),Y} = 10 \times \log\left(\sum_{i=1}^n 10^{\frac{C_{Ti,Y}}{10}}\right)$$

It is called comprehensive antenna isolation between $\{T_1, T_2, \dots, T_n\}$ and Y .

Figure 1

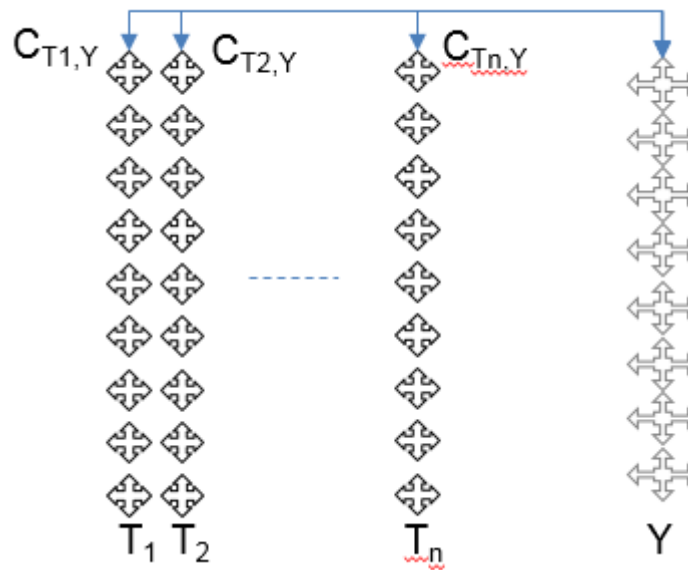

The benefit of comprehensive isolation is that when calculating the blocking and spurious emission of the $nTnR$, only the impact of a single TX on the RX needs to be calculated.

2.5 Conclusion

When Sub-3GHz base station antennas including 700 MHz (B28), 800 MHz (B20), 900 MHz (B8), 1500 MHz (B32), 1800 MHz (B3), 2100 MHz (B1), 2300 MHz (B40), FDD 2600 MHz (B7), and TDD 2600 MHz (B38) share antenna installation platforms or when these antennas are co-sited with C-band NR antennas, and if the system isolation is greater than 23 dB, spurious emission of the TX of the interfering system do not affect the receiver sensitivity of the interfered system. On the other hand, blocking does not affect the system even if there is no isolation between systems.

3 Isolation Calculation of Antennas Installed Horizontally and Horizontal Installation Distance Between Sub-3GHz Antennas and C-band NR Antennas

3.1 Theoretical Calculation of Isolation Between Two Antennas Horizontal Deployment

The following figure shows theoretical calculation of isolation between two antennas.

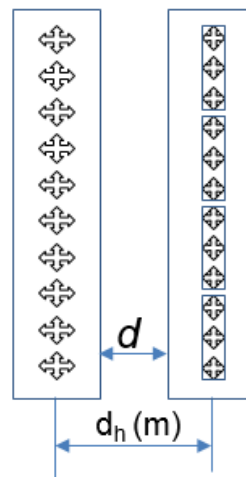

The formula for calculating the isolation of horizontal antennas is as follows:

$$I_H[\text{dB}] = 22 + 20 \lg(d_h f / c) + \sigma$$

where

$d_h(\text{m})$: Center distance of width between two antennas

$f(\text{Hz})$: Operating frequency of the operator

$c(\text{m/s})$: Rate of light in free space (about $3 \times 10^8 \text{ m/s}$)

σ (dB): Gain of the near-far field conversion. The value in engineering can be 10 dB ($d_v < 10 \text{ m}$) or 0 dB ($d_v > 10 \text{ m}$).

Antenna isolation of different frequency bands for different horizontal distances:

Horizontal Distance d_h (m)	Frequency Band						
	700	800	900	1400	1800	2100	2600
0.5	33	34	36	39	42	43	45
1	39	41	42	45	48	49	51
1.5	43	44	45	49	51	52	54
2	45	47	48	51	54	55	57
2.5	47	48	50	53	56	57	59
3	49	50	51	55	57	58	60
3.5	50	51	52	56	58	60	62
4	51	53	54	57	60	61	63

Note: d_h indicates the distance between the centers of the antenna arrays.

3.2 Test Result of Sub3GHz Antenna and C-band NR Antenna When They Are Placed Horizontally with Distance of 0.1 m

A vector network analyzer (VNA) is used to test the isolation of the Sub-3GHz antenna and the C-band NR antenna when they are placed horizontally. The edge-to-edge distance (d) is 0.1 m. According to Huawei antenna test results, when d equals 0.1 m, an isolation greater than 23 dB between Sub-3GHz base station antennas and C-band NR antennas can be achieved.

The following figure shows the test results of comprehensive isolation between four high-band antennas (h1, h2, h3, h4) or four low-band antennas (l1, l2, l3, l4) of Sub-3GHz base station 4T4R antenna and column m1 (closest to the Sub-3GHz antenna) on the C-band NR antenna.

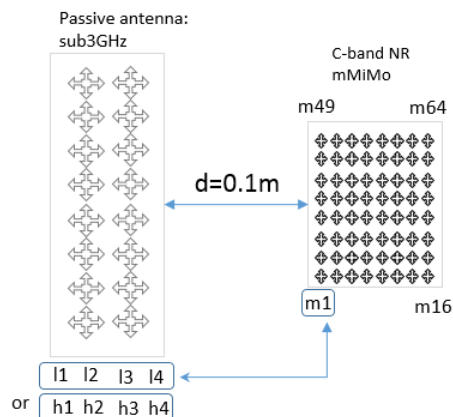

$I_{m,l}$ <p>Antenna(690-960M) VS 3.5G NR Antenna</p> $I_{m1,l} = 10 * \log\left(\sum_{i=1}^4 10^{\frac{I_{m1,li}}{10}}\right)$ <p style="color: red;">d=0.1m Max Value is -46.6dB</p>	$I_{m,h}$ <p>Antenna(1710-2690M) VS 3.5G Antenna</p> $I_{m1,h} = 10 * \log\left(\sum_{i=1}^4 10^{\frac{I_{m1,li}}{10}}\right)$ <p style="color: red;">d=0.1m Max Value is -49.7dB</p>
--	---

According to the test results, when the edge-to-edge distance is 0.1 m, the comprehensive isolation between the four low-band antennas (l1, l2, l3, l4) and m1 is better than 46.6 dB, and the comprehensive isolation between the four high-band antennas (h1, h2, h3, h4) and m1 is better than 49.7 dB.

The following figure shows the test results of comprehensive isolation between columns m1 through m64 on C-band NR antenna and high-band (h1) and low-band (l1) antennas on Sub-3GHz antenna closest to the C-band NR antenna.

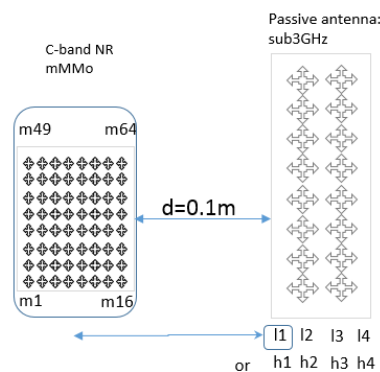

$I_{l,m}$ <p>Antenna(690-960M) VS 3.5G Antenna</p> $I_{l1,m} = 10 * \log\left(\sum_{i=1}^{64} 10^{\frac{I_{l1,mi}}{10}}\right)$ <p style="color: red;">d=0.1m Max Value is -35dB</p>	$I_{h,m}$ <p>Antenna(1710-2690M) VS 3.5G Antenna</p> $I_{h1,m} = 10 * \log\left(\sum_{i=1}^{64} 10^{\frac{I_{h1,mi}}{10}}\right)$ <p style="color: red;">d=0.1m Max Value is -30dB</p>
--	--

According to the test results, when the edge-to-edge distance is 0.1 m, the comprehensive isolation between the 64 columns of C-band NR antennas (m1 through m64) and l1 (low-band Sub-3GHz antenna closest to the high-band antennas) is greater than 35 dB, and the comprehensive isolation between the 64 columns of C-band NR antennas (m1 through m64) and h1 (high-band Sub-3GHz antenna closest to the high-band antennas) is greater than 30 dB.

3.3 Simulation of Impact of Horizontal Distance On Antenna Patterns

The following figure shows the simulation of horizontal placement of the Huawei Sub-3GHz antenna and C-band NR antenna.

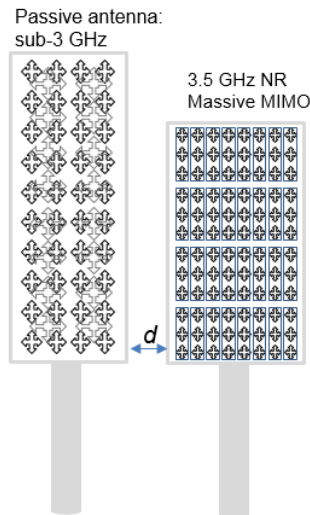

The following figures show the antenna patterns of Sub-3GHz antenna in the scenarios of without C-band NR antennas, with spacing of 0.1 m and 0.5 m.

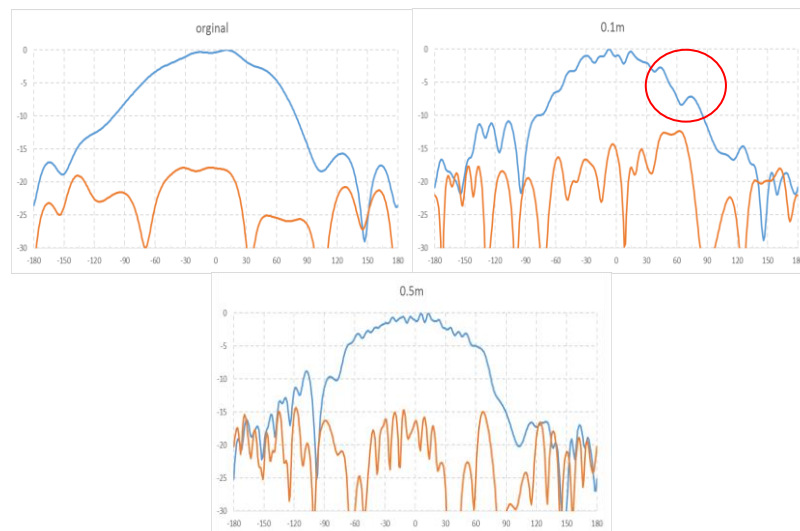

The simulation results show that when the horizontal distance is only 0.1 m, the gains of single-row beam with width being 30° to 60° (marked in the red circle) decrease.

The following figures show the antenna patterns of C-band NR 60° beam in the scenarios of without Sub-3GHz passive antennas with spacing of 0.1 m and 0.5 m.

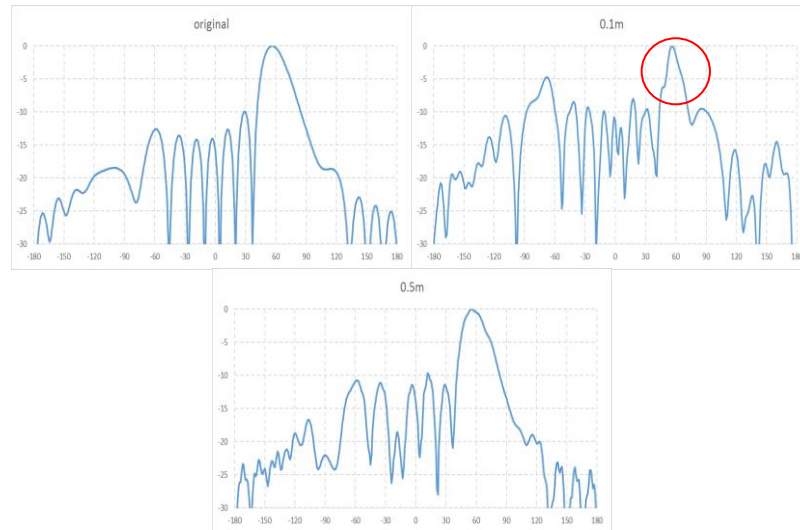

The simulation results show that when the horizontal distance is only 0.1 m, the 60° beam (marked in the red circle) is distorted.

The following figures show the antenna patterns of C-band NR 30° beam in the scenarios of without Sub-3GHz passive antennas with spacing of 0.1 m and 0.5 m.

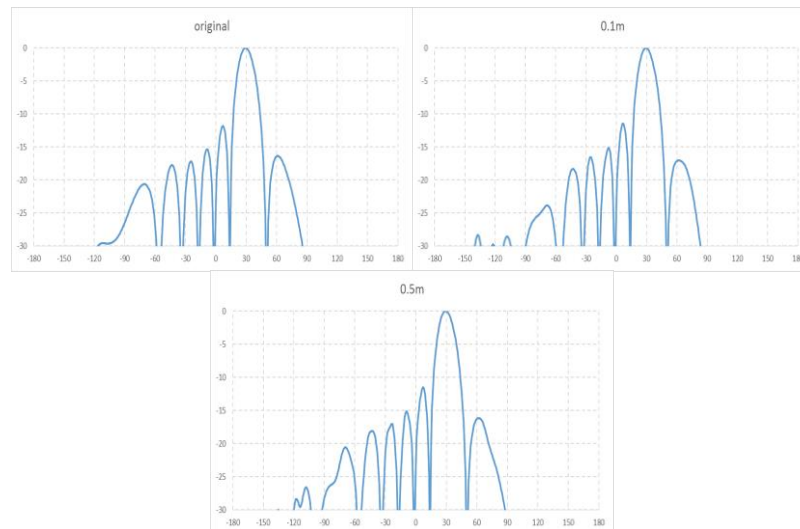

The simulation results show that when the horizontal distance is only 0.1 m, the impact on the 30° beam is low.

The antenna patterns show that when the edge-to-edge distance is 0.1 m, the horizontal sweeping effect of the beams within 30° is small. The sweeping within 60° has an impact. When the edge-to-edge distance is 0.5 m, the impact on the antenna patterns is small.

3.4 Conclusion

When the edge-to-edge distance (d) between Sub3GHz antennas and C-band NR antennas is 0.1 m, the impact of spurious emission and blocking on the system can meet the requirement of greater than 23 dB system isolation. However, when the impact of antenna pattern is considered, it is good to set the edge-to-edge distance (d) between Sub3GHz antennas and C-band NR antennas to a value greater than 0.5 m.

4 Isolation Calculation of Antennas Installed Vertically and Vertical Installation Distance Between Sub-3GHz Antennas and C-band NR Antennas

4.1 Theoretical Calculation of Isolation Between Two Antennas Vertical Deployment

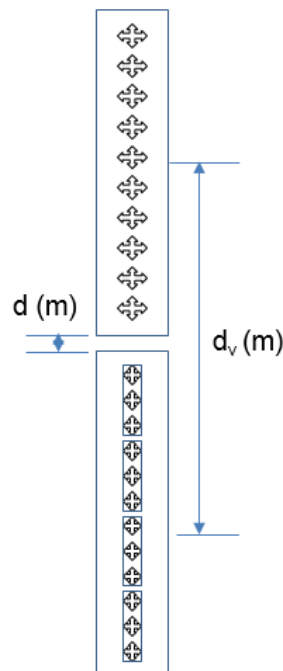

The formula for calculating the vertical isolation between antennas is as follows:

$$I_v [\text{dB}] = 28 + 40 \times \log(d_v/c) + \delta$$

Where,

d_v (m): distance between the center points of two antennas

δ (dB): gain of near-field-to-far-field transformation. The value can be -10 dB ($d_v < 10$ m) or 0 dB ($d_v > 10$ m) in terms of engineering.

d (m): the distance from edge to edge.

Table 4-1 Antenna isolation of different frequency bands with different vertical distances

Vertical Distance d_v (m)	Frequency Band						
	700	800	900	1400	1800	2100	2600
2	45	47	49	57	61	64	68
2.5	49	51	53	61	65	68	71
3	52	54	56	64	68	71	75
3.5	54	57	59	67	71	74	77
4	57	59	61	69	73	76	80
4.5	59	61	63	71	75	78	82
5	61	63	65	73	77	80	83
5.5	62	65	67	74	79	81	85
6	64	66	68	76	80	83	87

4.2 Test Result of Vertical Isolation Between a Sub3GHz Antenna and a C-band NR Antenna Without Spacing

Use a vector network analyzer to test the vertical isolation between a Sub-3GHz antenna and a C-band NR antenna when the edge-to edge distance (d) between these two antennas equals 0 m. According to Huawei antenna test results, the requirements on the isolation (> 23 dB) can be met.

The following shows the test results of comprehensive isolation between the four columns (h1, h2, h3, and h4) of a high-band Sub-3GHz 4T4R antenna and the column (m1) of a C-band NR antenna, and between the four columns (l1, l2, l3, and l4) of a low-band Sub-3GHz 4T4R antenna and the column (m1) of a C-band NR antenna. The column m1 is the column closest to the Sub-3GHz antenna.

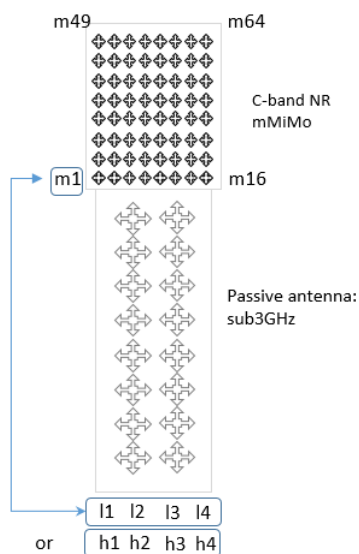

<p style="text-align: center;">$I_{m,l}$ Antenna(690-960M) VS 3.5G Antenna</p> $I_{m1,l} = 10 * \log\left(\sum_{i=1}^4 10^{\frac{I_{m1,li}}{10}}\right)$ <p style="text-align: center; color: red;">d=0 m Max Value is -51.5dB</p>	<p style="text-align: center;">$I_{m,h}$ Antenna(1710-2690M) VS 3.5G Antenna</p> $I_{m1,h} = 10 * \log\left(\sum_{i=1}^4 10^{\frac{I_{m1,li}}{10}}\right)$ <p style="text-align: center; color: red;">d=0 m Max Value is -56.7dB</p>
---	---

According to the test results, when the edge-to-edge distance (d) equals 0 m, the comprehensive isolation between four columns (l1, l2, l3, and l4) and the column m1 is greater than 51.5 dB, and the comprehensive isolation between four columns (h1, h2, h3, and h4) and the column m1 is greater than 56.7 dB.

The following shows the test results of comprehensive isolation between the columns (m1, m2, ..., and m64) of a C-band NR antenna and the column (h1) of a high-band Sub-3GHz antenna, and between the columns (m1, m2, ..., and m64) of a C-band NR antenna and the column (l1) of a low-band Sub-3GHz antenna. The column h1 or l1 is the column closest to the C-band NR antenna.

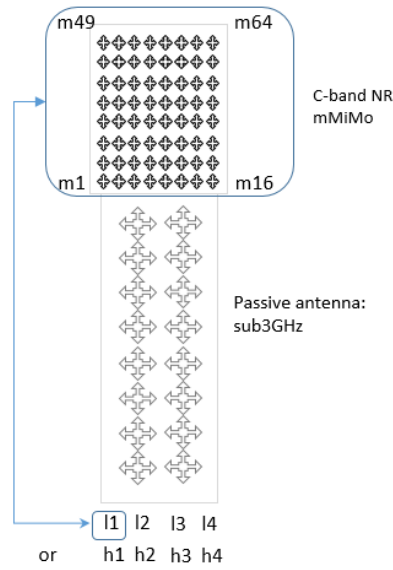

$I_{h,m}$ <p>Antenna(690-960M) VS 3.5G Antenna</p> $I_{h1,m} = 10 * \log\left(\sum_{i=1}^{64} 10^{\frac{I_{h1,mi}}{10}}\right)$ <p style="text-align: center; color: red;">d=0 m Max Value is -40dB</p>	$I_{l,m}$ <p>Antenna(1710-2690M) VS 3.5G Antenna</p> $I_{l1,m} = 10 * \log\left(\sum_{i=1}^{64} 10^{\frac{I_{l1,mi}}{10}}\right)$ <p style="text-align: center; color: red;">d=0 m Max Value is -35dB</p>
---	---

According to the test results, when the edge-to-edge distance (d) equals 0 m, the comprehensive isolation between 64 columns (m1, m2, ..., and m64) and the column l1 is greater than 40 dB, and the comprehensive isolation between 64 columns (m1, m2, ..., and m64) and the column h1 is greater than 35 dB.

4.3 Simulation of Impact of Vertical Distance On Antenna Patterns

Simulations are performed for a Sub-3GHz antenna and a C-band NR antenna positioned vertically to each other.

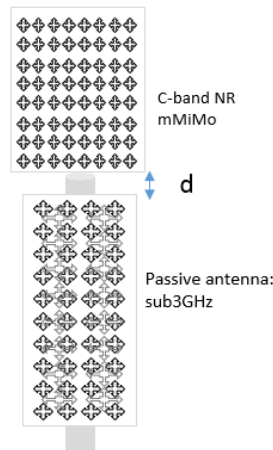

The following figures show the simulated patterns when the direction (d) equals 0 m.

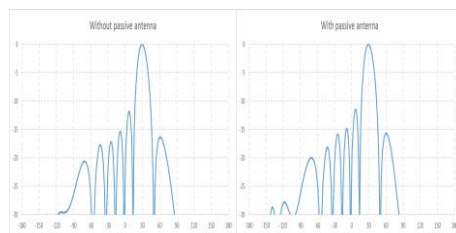

30° steering sweep beam pattern

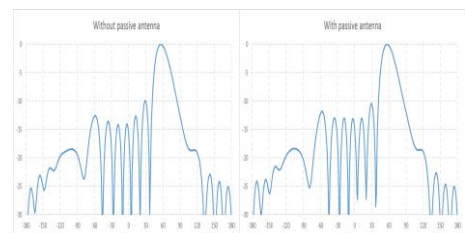

60° steering sweep beam pattern

Simulation results: There is no impact on the antenna patterns even if the edge-to-edge distance d of the two antennas equals 0 m.

4.4 Conclusion

There is no requirement on the vertical edge-to-edge distance between a Sub3GHz antenna and a C-band NR antenna in terms of system isolation and the impact on antenna pattern.

5 Isolation Calculation of Antennas Installed Slantly and Slant Installation Distance Between Sub-3GHz Antennas and C-band NR Antennas

5.1 Theoretical Calculation of Isolation Between Two Antennas Slant Deployment

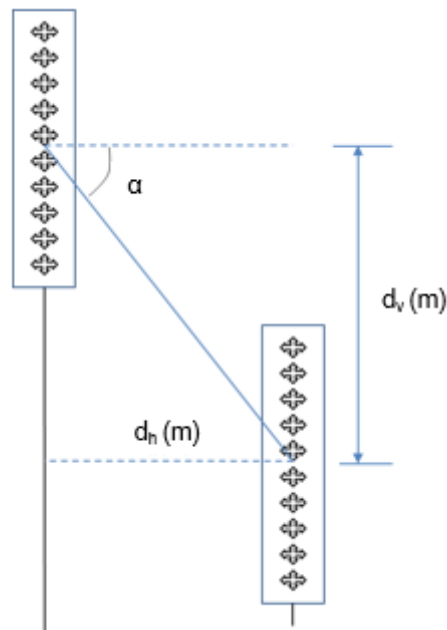

The formula for calculating the slant isolation between antennas is as follows:

$$I_s \text{ [dB]} = (I_v - I_h) \times (\alpha / 90^\circ) + I_h$$

Where,

I_s : The slant isolation between antennas

I_h : The horizontal isolation between antennas

I_v : The vertical isolation between antennas

α ($^\circ$): The horizontal plane is regarded as 0° , and the clockwise direction is used.

The slant isolation can be calculated after the vertical and horizontal isolations are calculated.

Example:

Assume that the Sub-3GHz antenna is 2 m long and 0.298 m wide, and the C-band NR antenna is 0.8 m long and 0.395 m wide. If the horizontal edge-to-edge distance equals 0.5 m and α equals 45° , the relationship between the vertical edge-to-edge distance and the antenna isolation is listed in the following table.

Table 5-1 Antenna isolation of different frequency bands with different vertical edge-to-edge distances

Distance d (m)	Frequency Band				
	700	800	900	3500	3700
0.5	42	44	45	62	62
1	44	46	47	64	64
2	47	49	50	67	67
3	49	51	52	69	70
4	51	53	54	71	71
5	53	54	56	72	73
6	54	55	57	74	74
7	55	57	58	75	75
8	56	58	59	76	76

5.2 Conclusion

According to the real scenario, $I_h < I_s < I_v$ when antennas are slantingly configured. The two antennas will not affect the systems when the horizontal edge-to-edge distance is greater than 0.5 m.

6 Inter-System Deployment in One Region Using Different Base Stations

When different operators deploy base stations in the same region (as shown in the following figure), the antenna isolation is calculated using the following formula.

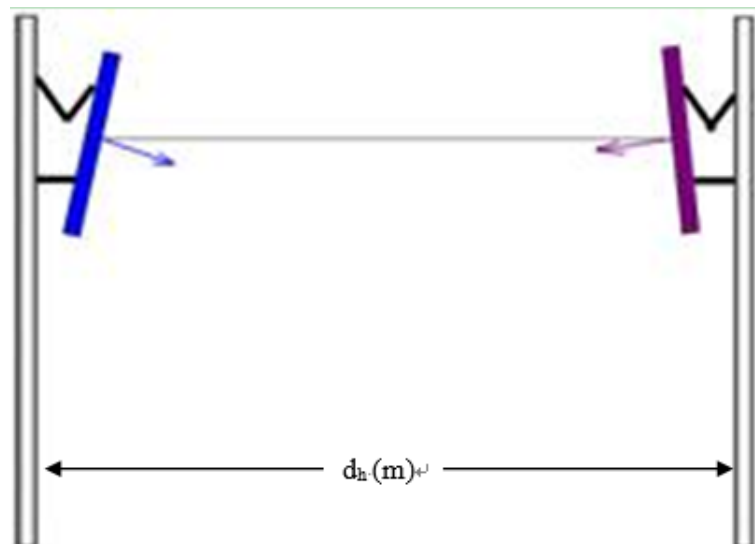

$$I_H \text{ [dB]} = 22 + 20\log(d_h f/c) - (G_{Tx} + G_{Rx}) - [SL(\rho)_{Tx} + SL(\theta)_{Rx}]$$

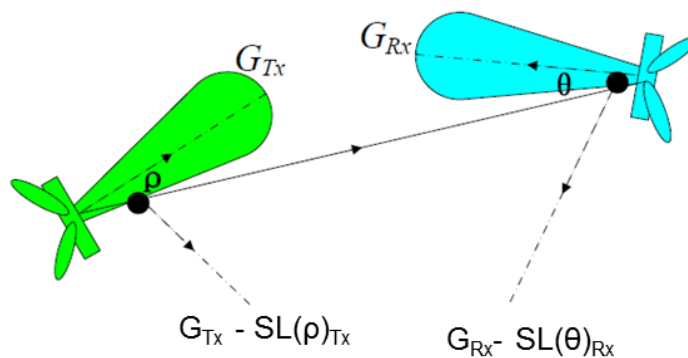

Where,

- G_{TX} represents the gain of the TX antenna.
- G_{RX} represents the gain of the RX antenna.
- $SL(\rho)_{TX}$ represents the side-lobe gain with respect to the main lobe of the TX antenna.
- $SL(\theta)_{RX}$ represents the side-lobe gain with respect to the main lobe of the RX antenna.
- $SL(\rho)_{TX}$ and $SL(\theta)_{RX}$ can be obtained from the antenna pattern file, such as the MSI file.

Example:

Assuming that the average site height is 30 m, the antenna gain is 17 dBi, the vertical beamwidth is 6°, and the downtilt is 3°, the relationship between antenna distance and antenna isolation is listed in the following table.

Table 6-1 Antenna isolation of different frequency bands with different antenna distances

Antenna Distance (m)	Frequency Band					
	700	800	900	1800	2100	2600
100	41	42	43	50	51	53
200	47	48	50	56	57	59
300	51	52	53	59	60	62
400	53	55	56	62	63	65
500	55	56	57	63	65	67
600	57	58	59	65	66	68
700	58	59	60	66	68	70
800	59	61	62	68	69	71
900	60	62	63	69	70	72
1000	61	62	63	70	71	73

7 Summary

Based on the requirements of spurious interference, blocking interference, and antenna pattern for the antenna installation distance, the following conclusions can be made:

- The system isolation between a Sub-3GHz antenna and a C-band NR antenna in one base station must be better than 23 dB.
- The horizontal distance (d) between a Sub-3GHz antenna and a C-band NR antenna in one base station must be larger than 0.5 m.

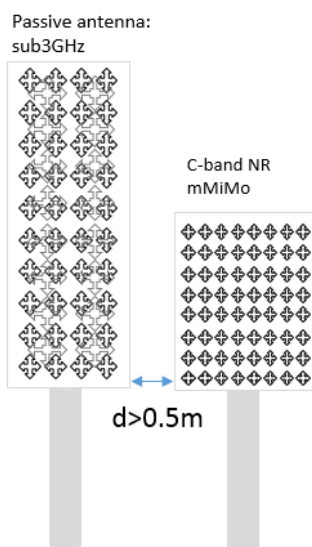

- There is no requirement on the distance between a Sub-3GHz antenna and a C-band NR antenna that are vertically configured at the same base station site. The distance can be determined based on requirements on heat dissipation of modules or engineering maintenance.

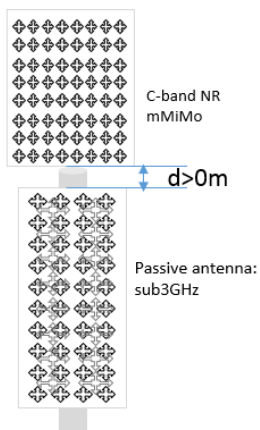

8 Reference

- [1] Isolation between antennas of IMT base stations in the land mobile service
- [2] 3GPP TS 36.104 V13.2.0 (2016-01)